



## AT SEAT SOCKET POWER SUPPLY (ASPS) – DIESEL MULTIPLE UNIT (DMU) DC-AC CONVERTER (24Vdc – 230Vac)

TPS is one of the pioneers in designing ASPS with over 1200 units successfully operating in trains all over the UK. These units are ruggedised and robust, suitable for installation into challenging transport applications such as trains, metro rail and buses. This datasheet focuses on 24Vdc input ASPS for DMUs. The 24Vdc ASPS provides a high quality fully regulated 230Vac 50Hz output to supply demanding non-linear loads such as mobile phones and laptops.

### Key benefits:

- ✓ Power rating of 700W – nominal across the range
- ✓ Compact & lightweight design
- ✓ Multiple units to achieve additional sockets
- ✓ Naturally cooled for ease of integration
- ✓ Silent operation
- ✓ High quality true sinewave output
- ✓ Superior waveform quality with 3% THD
- ✓ Simple installation
- ✓ Wide input voltage design
- ✓ High reliability
- ✓ High efficiency
- ✓ Ruggedised & robust design
- ✓ Various mounting options available
- ✓ Low maintenance
- ✓ Diagnostic software included
- ✓ Single LED status indication
- ✓ Fully rail approved
- ✓ Performs to BS/EN 50155 standards



## Performance Table

### General

Maximum Output Power	700W Continuous (110% rated power for 30 seconds)
Output Voltage at frequency	230Vac at 50 Hz
Input Voltage Range	20Vdc to 34Vdc
Efficiency	92% at 700W / 86% at 350W
Harmonic Distortion (monitored)	< 3%
Dimensions	500mm x 240mm x 132mm (L x W x H)
Weight	6 kg

### Protection

Input Protection	Reverse polarity diode protection / Surges & Transients to RIA 12
Inrush Current	6 x nominal current
Galvanic Isolation	1.5 kV ac rms
Environmental	IP54
Functional Protection	Thermal Protection / Overload / Earth Leakage RCD / Short Circuit

### Environmental

Ambient Temperature	-25°C to + 40°C
Storage Temperature	-40°C to + 80°C
Relative Humidity	95% max
Environmental	IP54
Shock & Vibration	EN 61373, RIA 20
EMC	EN 50155, EN 50121-3-2
Cooling	Natural Convection (Max plate temperature X°C)

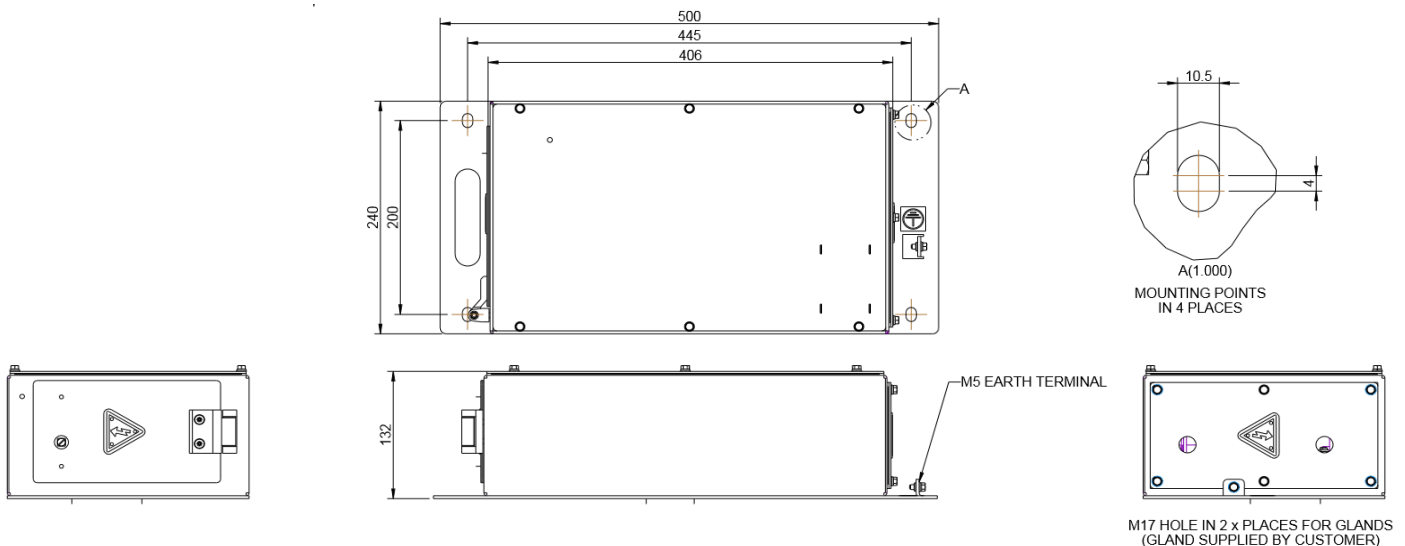

Our ASPS assures that your passengers can charge their mobile phone/laptop and leave the train with a fully charged device to continue on their day's business. We will be happy to discuss your project or enquiries, please contact our marketing department at [marketing@turbopowersystems.com](mailto:marketing@turbopowersystems.com) or ring us on +44 (0) 191 482 9288/9251/9278.

